

LVS propose une gamme d'écrans mobiles extérieurs de haute qualité. La mise en œuvre est rapide, et l'esthétique globale est épurée sans camions en dessous, pas de grandes structures, pas de roues ou autres équipements visibles, une seule colonne de support au milieu. Ce qui en fait un support parfait pour des événements extérieurs d'exception.

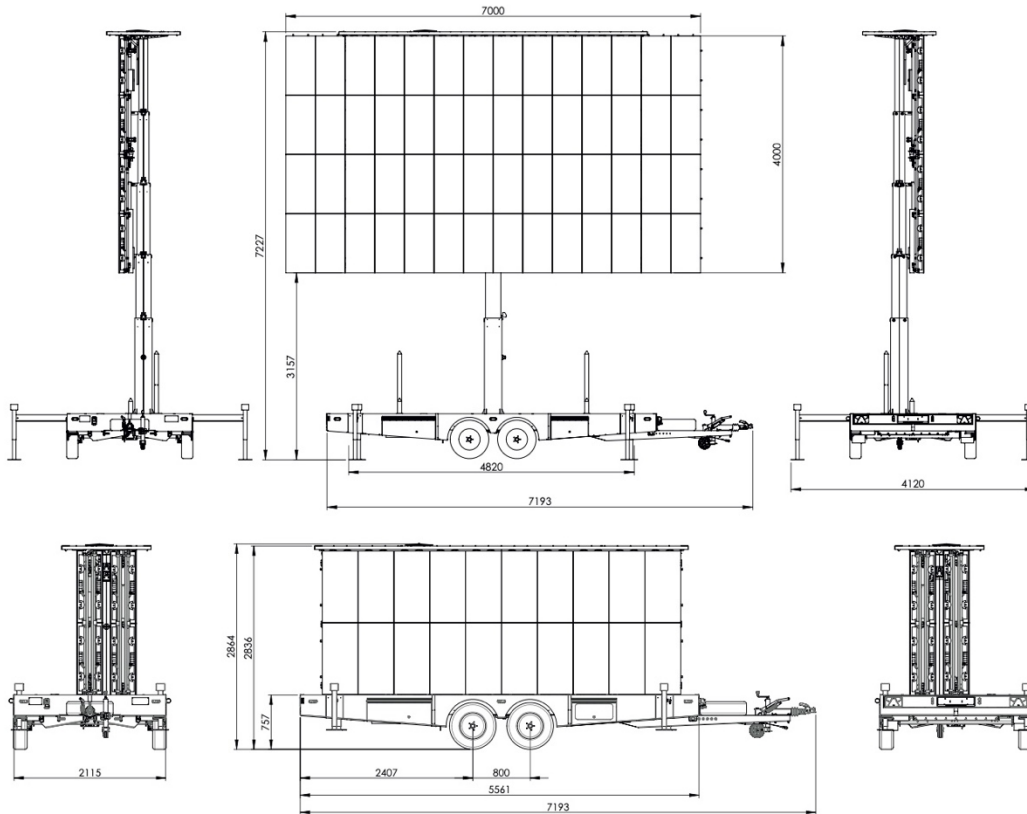

DIMENSIONS FOR TRANSPORT

Lenght with drawbar	7193 mm
Lenght without drawbar	5561 mm
Width	2115 mm
Height	2864 mm

DIMENSIONS WITH UNFOLDED SCREEN

Width	4120 mm
Lenght	7913 mm
Height to top of the screen	7227 mm
Height to bottom of the screen	3157 mm

WEIGHT

GVWR weight	3500 kg
Real weight with the screen	≈ 3500 kg
Real weight without the screen	≈ 2650 kg

LED SCREEN DETAILS

Area	28 m ²
Width	7 m
Height	4 m
Dimensions de déploiement au sol: 9m x 3,80m	
Resolution P3.91	1792 x 1024 px
Ecran Full Black Face – 3800 cd/m ² – Pitch 3.9	
Videoprocessor	Novastar 2x VX4S (P3.91) or VX4S (P4.63)

Remorque Video LED 28m2 - Pitch 3.9 Black Legend



HYDRAULIC SYSTEM

Motor power	1,5 kW (400V)
Flow rate	6 dm ³ /min
Nominal pressure	11 MPa
Oil type	HL46 or HL32 (for lower temperatures)
Oil quantity	= 40 dm ³

POWER

Power socket	400V 32A
Power generator	✗
GXII screen turned on Max. power consumption (InflLED GXII)	19,04 kW
Power supply Needed : Minimum 26KVA / 3P +N + E / 400V / 32	
Ledscreen Average Power Consumption: 6,72 kW	
Ledscreen Max Power Consumption: 20,160 kW	
Screen wings Power consumption (open, close)	0,5 kW
Other equipment Power consumption (wind sensor, video processor etc.)	max. 0,5 kW

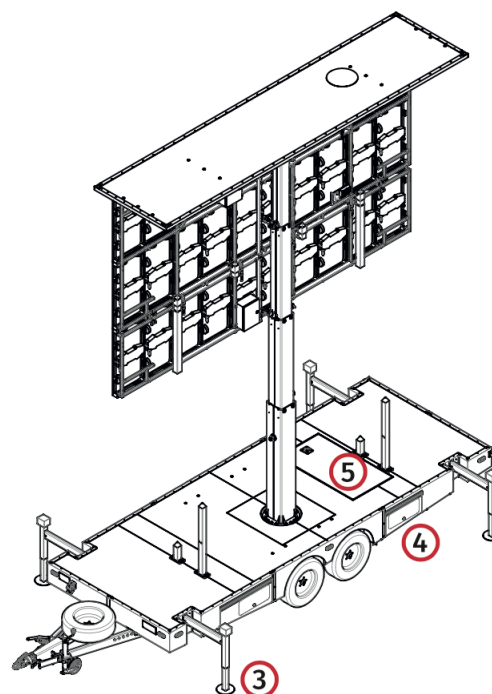
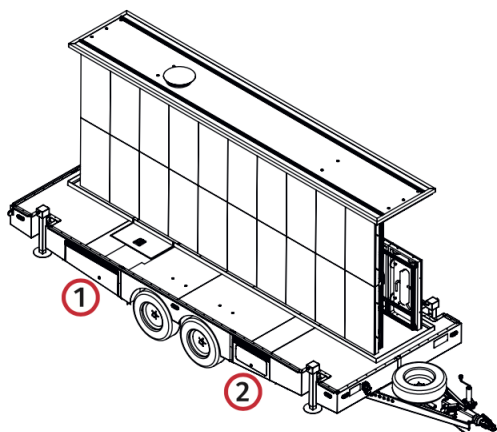

STORAGE BOXES

1	electrical box
2	Hydraulic levers and hand pump
3	Rack 19" 2U and 2x 230V sockets
4	fire extinguisher , remote controller, outrigger's key, grounding rod, elastic rope for secure tarpaulin, key for tarpaulin folding
5	hydraulic pump engine and oil tank

CONSTRUCTION

Chassis	Galvanized, made according to DIN EN 13814 and DIN EN 13782
Axles and brakes	2x AL-KO
Mast	360° hydraulic rotated , galvanized and black powder coated
Mast control	remote controller, hydraulic levers and emergency hand pump
Finishing	aluminium profile, powder coated
Color	in standard - black additional fee - any from RAL
Wind rating	20 m/s (72 km/h) 15 m/s for TÜV norms (DIN EN 13814)
Wind sensor	according to DIN EN 13814 (with alarm)

OTHER DETAILS

Wind rating	20 m/s (72 km/h) 15 m/s for TÜV norms
IP rating	IP65 (fully waterproof)
Road approval	EU road approval
Cover for transport	dual axle
Mast control	remote controller, hydraulic levers and emergency hand pump
Warranty	3 years

LVS – Led Vidéo Solution - 01 84 24 04 33

Bureaux : 200 chaussée Jules César – 95250 Beauchamp – France
Entrepôts : 7 Rue de Folenrue – 27200 Vernon – France
www.lvs.paris

Remorque Video LED 28m2 - Pitch 3.9 Black Legend



LVS – Led Vidéo Solution - 01 84 24 04 33

Bureaux : 200 chaussée Jules César – 95250 Beauchamp – France
Entrepôts : 7 Rue de Folenrue – 27200 Vernon – France
www.lvs.paris